

## Dimensions - Side View

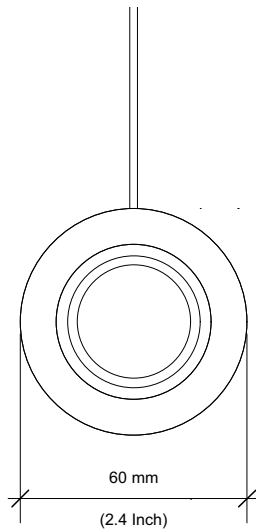

## Dimensions - Down light

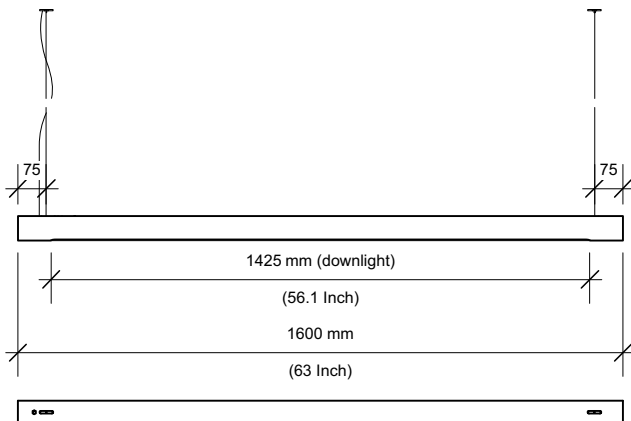

## Dimensions - Up & down light

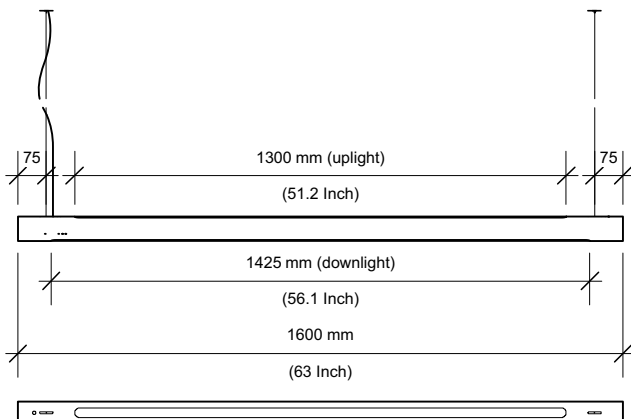

## Design by

Thomas Housden

## Material & finish

Ceramic extrusion, aluminium core, silicone end caps

## Dimensions & weight

Downlight option:

L.1600 / Ø60 mm, 7kg

L.63inch / Ø2.4inch, 15.4lb

Up & downlight option:

L.1600 / Ø60 mm, 6kg

L.63inch / Ø2.4inch, 13.2lb

## Lamp type & wattage

USA 12V DC LED 20w per metre

2700K or 3000K colour temp

## Power supply

USA Standard driver supplied

Optional interfaces/power supplies eg Dali, 1-10V, wall mounted dimmer module, remote control module.

## Wiring certification

CE / UKCA, BS-EN60598 IP20

UL Listed 'damp' rated

## Options

Down light

Up & down light



- Please read these instructions IN FULL and carefully BEFORE commencing assembly and installation
- We recommend the use of a professional trades person with suitable qualifications for the installation of electrical lights
- Install the light in conformity with all relevant local building codes and regulations.
- Two people are required for the safe installation of the O-Beam light
- Products with electronic ballast / drivers must not be installed on the same electrical circuit as products with inductive loads, for example magnetic fluorescent luminaries, motors or ventilators. Inductive loads can generate excessive voltage surges and can damage electronic ballasts
- Ensure correct connection of cables (positive / negative). the LED will not work if polarity is reversed.
- This lamp is made of ceramic. Caution should be taken not to hit the lamp with heavy objects that could cause the ceramic to break. The lamp has a bonded aluminium core to prevent structural failure. Sharp parts and fragments may crack off the lamp in the event of impact.
- Always use this lamp either above a table / work surface or at a height above head height. The lamp is solid and heavy so the possibility of walking into the lamp should be avoided
- Do not hang off the lamp or lean on the lamp to avoid adding weight to the lamp and suspension system. The lamp is designed to take over 30kg per suspension cable but the fixing to the ceiling load capacity will depend on the installation and is not designed to support excessive loading.
- If you want to source your own power supply, make sure that this is CLASS 2 and suitable for the LED strip supplied (ie 12 or 24v DC) constant voltage.
- LED light source must be replaced only by the manufacturer or a similarly qualified person.
- If the external cables are damaged, they must be replaced by the manufacturer or a similarly qualified person.
- Used electrical equipment (WEEE) should not be mixed with general household waste. Please recycle. Our products can be dismantled prior to disposal.

## Diagram 1

Lamp components

1. USA only: Raco 4 inch octagonal ceiling box and screws (not supplied)
2. Ceiling fixing plates x2 (with 3 screw holes, screws not supplied)
3. Super clamps for steel cable x2
4. Cover plates x2  
(one is the snowman shape, the other is small and round)
5. Cord grip/flex grommets x2 (one is for optional use)
6. Power flex cord
7. Steel uspension cables x2
8. Ceramic beam
9. Aluminium core and heat sink
10. LED strip(s)
11. Diffuser(s)
12. Silicone end bungs x2

## Components list

The O-Beam will come assembled with only parts 1-5 NOT assembled. Follow the steps below to install the lamp.

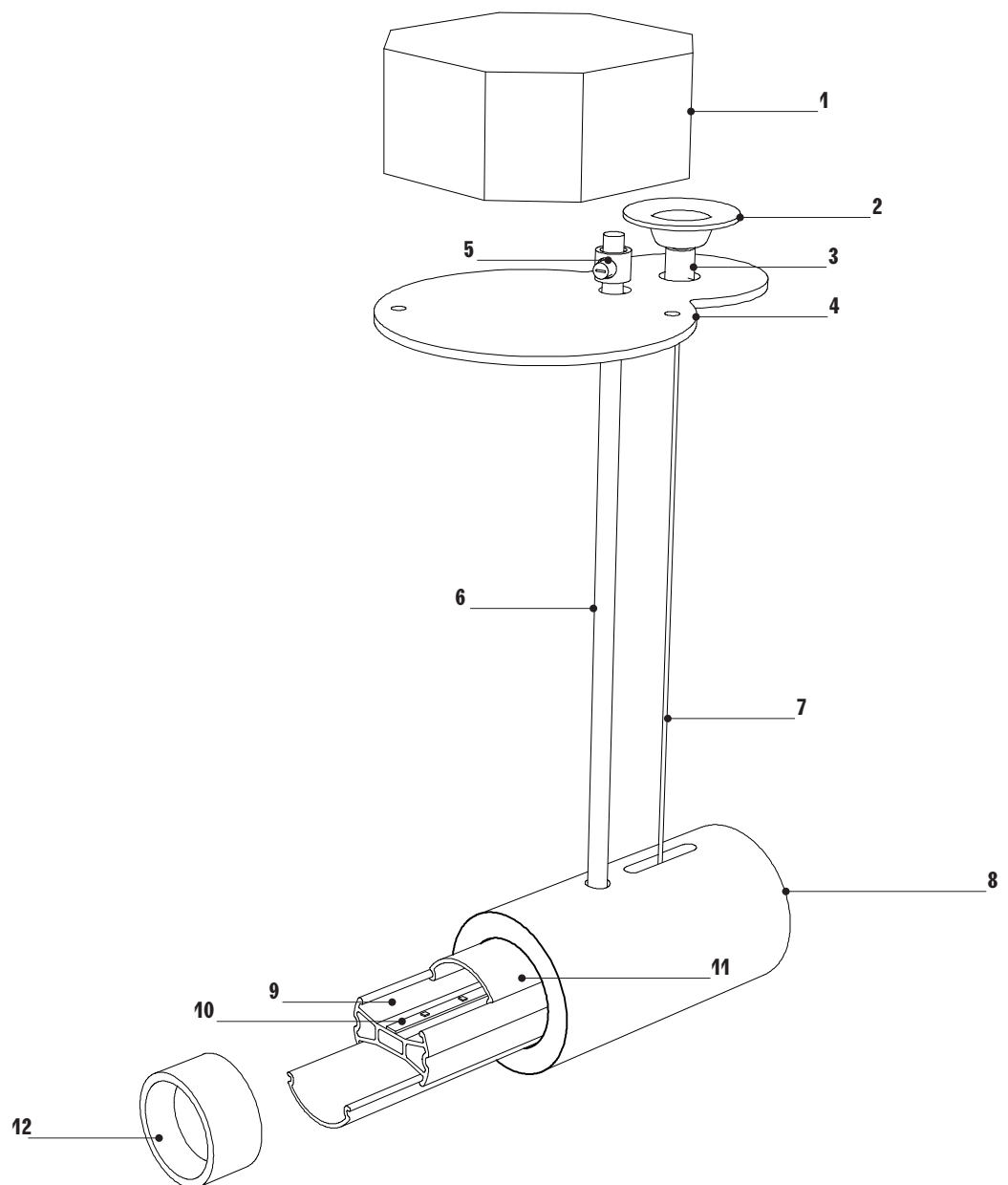

**Diagram 2**

Ceiling fixing power flex side

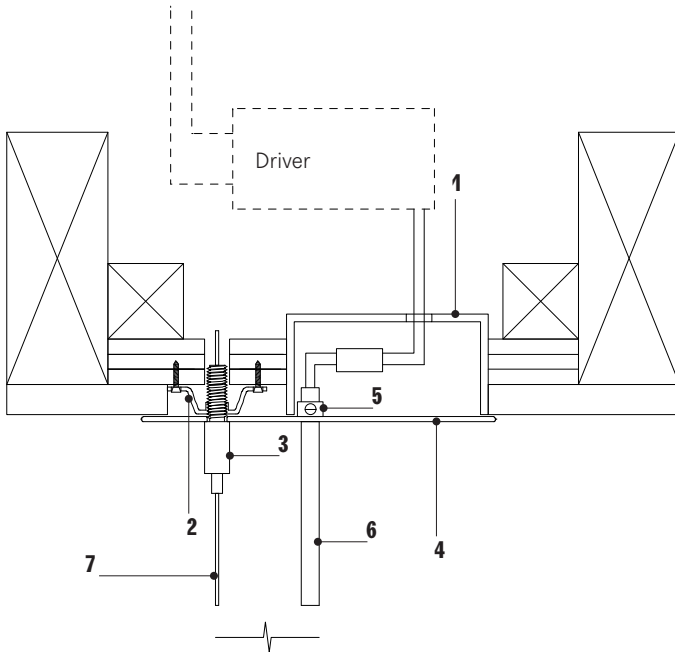

**Diagram 3**

Back box cover plate

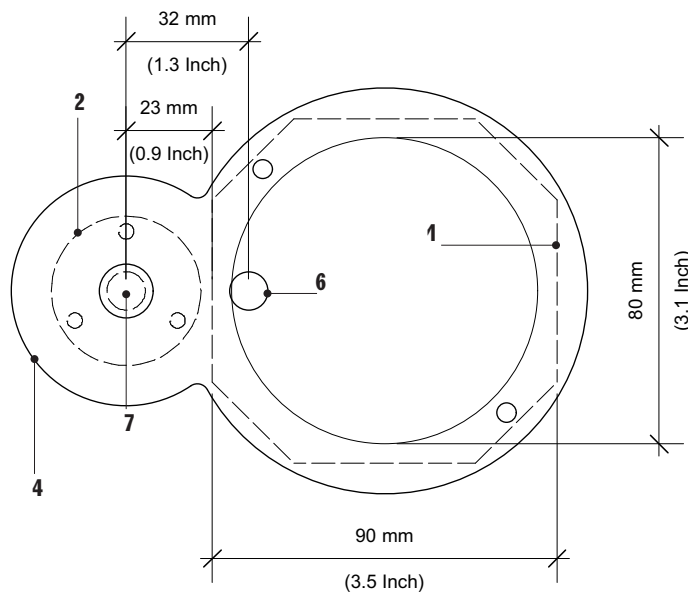

## Note!

- The O-Beam weighs 13-15.5lb so it is important that it is securely attached. This task requires TWO people. Make sure the ceiling substrate is suitable for the weight. We recommend allowing for a plywood pattress behind the ceiling.

## Steps

### 1 Locating hanging position

Locate the hanging position for the lamp. The suspension fixing points are located 57 inches apart if the lamp is hung horizontally. Mark up the suspension points on the ceiling and drill a centre hole to allow the superclamp (3) to go through the ceiling (21/64 inch drill).

If the lamp is being hung at an angle the distance between the suspension points will change as follows:

10 degrees	= 56.2 inches
15 degrees	= 55.1 inches
20 degrees	= 53.6 inches
25 degrees	= 51.7 inches
30 degrees	= 49.4 inches
35 degrees	= 46.7 inches

### 2 Back box installation

Secure suitable Racco 4 inch octagonal ceiling back box (1). The back box will not take the load of the lamp and is only provided to make the electrical connection behind the ceiling.

## Note!

- The back box needs to be located as shown in diagram 3 relative to the suspension point.

### 3 Securing fixing points

Secure the suspension fixing plates (2) to the ceiling. Ensure these are suitably fixed in to a suitable substrate. Thread the superclamps (3) in to the fixing plates (2). Ensure the fixing clamp (2) is flush with the finished ceiling.

The suspension only side of the lamp does not have a back box. See diagram 3&4.

## Note!

- The driver can be located anywhere within 32 feet from the lamp. We recommend locating the driver in an accessible location. If the driver is located in the ceiling ensure it has free air circulation. Your electrician should advise on suitable locations and pre wire this in to the build.

**Diagram 4**

Suspension side only fixing diagram

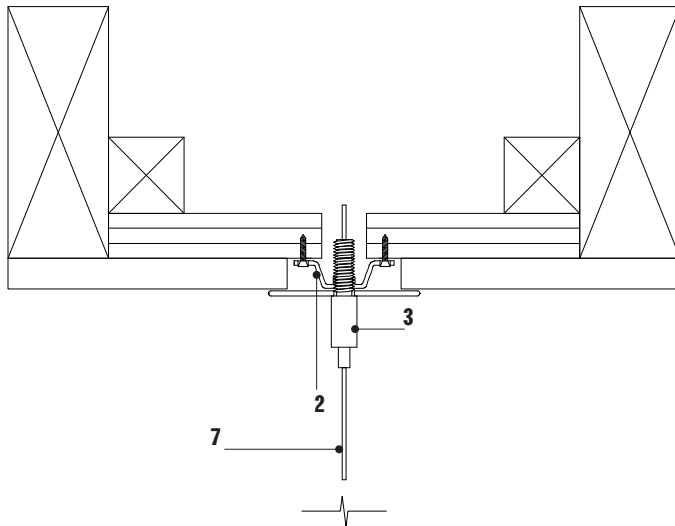

**Diagram 5**

Wiring diagram

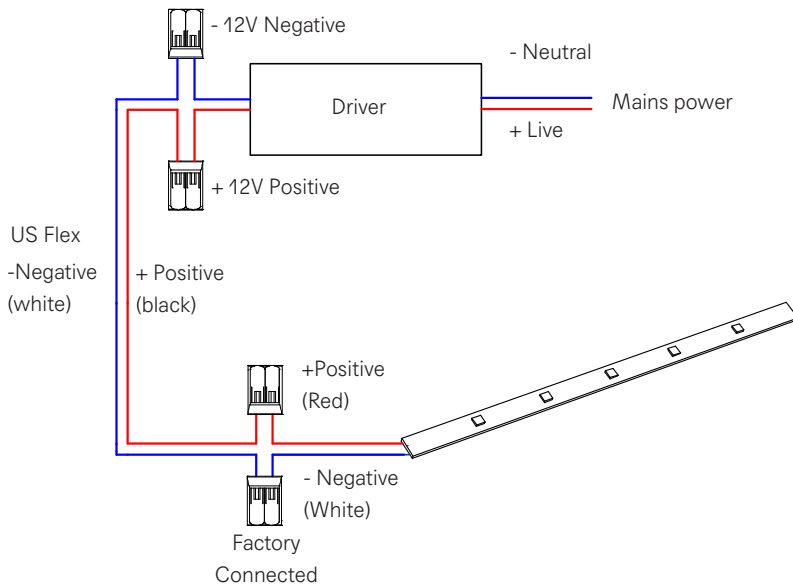

#### 4 Ceiling rose setup

Thread the flex cable (6) through the back box cover plate hole (6). Thread the suspension cable (7) through the back box hole (7). Gently rest the cover plate on top of the lamp.

#### 5 Fixing to super clamps

Thread the suspension cables (7) through both super clamps and lift the lamp to the desired height. The clamps will automatically grip the cable. To release the cable, push up on the super clamp nipple whilst pulling the cable. Make sure someone is holding the lamp securely!

#### 6 Connecting the flex

Fit the black flex grommet (5) over the flex end. Lift the back box cover (4) plate up to the ceiling and determine the desired length of the flex. Cut any excess flex off. Secure the black grommet (5) at the back of the cover plate. See diagram 2 & 3.

#### Note!

- Make sure mains power is OFF during installation and use a qualified tradesman.
- The flex power cord must not be in tension and should not take any of the weight of the lamp.

#### 7 Connecting the power

Connect the power cord flex (6) to the driver power cable inside the back box using the supplied Wago connection blocks. See diagram 5 for wiring set up and colours.

#### Note!

- The LED and flex cable are pre connected in the factory
- Ensure the lamp flex cable have been suitably stripped to allow a good contact inside the Wago connectors provided.
- Do not reverse polarity
- The O-beam LED has 12V input. Do NOT connect directly to the mains power but use the driver provided.

---

## Diagram 6

Finished installation

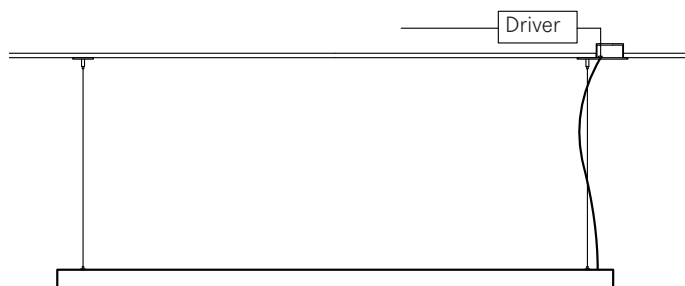

- 8** If desired, the flex cord can be kept close to one of the steel suspension cables using the additional flex grommet supplied. Make sure that the flex cord and steel cable are both threaded through the grommet BEFORE fitting the cover plate and making the connections.

**9 Finished installation**

Diagram 5 shows the final set up of the O-beam. The light should be hanging securely from the ceiling with the suspension cables running vertically.

The driver is located above the ceiling or located remotely in a cupboard or accessible location. This must not be more than 10 metres away.